

KONOVEN TORO-10

KONVENKSIYONEL FIRIN
HEISLUFTHERD
CONVECTION OVEN
КОНВЕКЦИОННЫЕ ПЕЧИ

www.konoven.com





BİLGİ
INFORMATION
ИНФОРМАЦИЯ
INFORMIEREN



TORO-10

Konveksiyonel Fırın
Convectional Oven

Heißlufttherd
конвекционные печи



360 Derece homojenize ısı dağılımı, verimi maksimize eden AR-GE merkezinde geliştirilen üst düzey teknolojiyle donatılan TORO Döner Konveksiyonlu Fırınımız hizmetinizde. Fırınımız 360 derece ısı ve buhar dolaşımı sayesinde pişen ürünlerin her noktadan pişmesini sağlar. Özel geliştirilmiş dokunmatik panel sayesinde fırının bilgilerini , pişirme seçeneklerini istenilen ayarda takip etmenizi ve düzenleme kontrolünü sağlamanıza yardımcı olur.. Pişirme kaynağı elektrikli ve doğalgazlı modelleri vardır.İstenilen tava ebatlarında ve kat sayılarında üretimimizi özelleştirme seçeneği sizlerle.



TORO, ein rotierender Konvektionsofen, der mit Spitzentechnologie ausgestattet ist, die im Forschungs- und Entwicklungszentrum entwickelt wurde, um die Effizienz und die homogenisierte Wärmeverteilung um 360 Grad zu maximieren, steht Ihnen zur Verfügung. Unser Ofen sorgt dank 360-Grad-Hitze und Dampfzirkulation dafür, dass die gekochten Produkte von jedem Punkt aus gegart werden. Dank des speziell entwickelten Touch-Panels hilft es Ihnen, die Informationen des Ofens zu verfolgen, die Garoptionen auf die gewünschte Einstellung zu stellen und die Regulierung zu steuern. Die Kochquelle ist Elektro- und Erdgasmodelle. Die Möglichkeit, unsere Produktion anzupassen in den gewünschten Pfannengrößen und Anzahl der Schichten liegt bei Ihnen.



TORO, Rotary Convection Oven equipped with high-level technology developed in the R&D center that maximizes efficiency and 360-degree homogenized heat distribution, is at your service. Our oven ensures that the cooked products are cooked from every point, thanks to 360-degree heat and steam circulation. Thanks to the specially developed touch panel, it helps you to follow the information of the oven, cooking options at the desired setting and to control the regulation. The cooking source is electric and natural gas models. The option to customize our production in the desired pan sizes and number of layers is with you.



К вашим услугам ротационная конвекционная печь TORO, оснащенная высокотехнологичной технологией, разработанной в научно-исследовательском центре, которая обеспечивает максимальную эффективность и гомогенизированное распределение тепла на 360 градусов. Наша печь гарантирует, что приготовленные продукты будут приготовлены со всех сторон, благодаря 360-градусному нагреву и циркуляции пара. Благодаря специально разработанной сенсорной панели он помогает вам следить за информацией о духовке, опциях приготовления при желаемой настройке и контролировать регулирование. Источником приготовления пищи являются электрические модели и модели, работающие на природном газе. Возможность настроить наше производство в желаемых размерах кастрюли и количество слоев с вами.

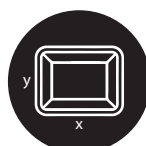

ELEKTICAL	2130*995*1230	2200*1000*1300	400*600	26,6 kW/h	Electric	Dijital, Manuel	23,1 kW
GAS	2130*995*1230	2200*1000*1300	400*600	4,5 kW/h	Gas	Dijital, Manuel	1 kW



ELEKTICAL	E=3P+N+PE	20.000 Kcal/24kW	400C°	10 Adet	3,5 kW	1,44m ²	482 kg
GAS	G=1P+N+PE	20.000 Kcal/24kW	400C°	10 Adet	3,5 kW	1,44m ²	500 kg

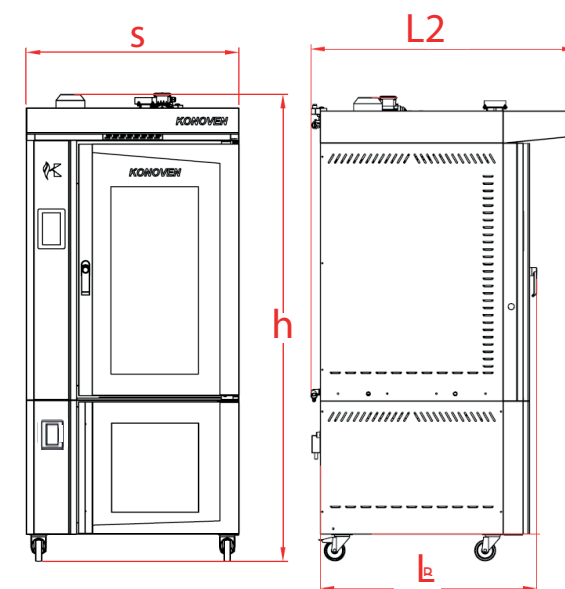

MERKEZ FABRİKA-HEADQUARTERS/FACTORY

Fevziçakmak Mah. Sıla Caddesi

No:46H, 42210 Karatay/Konya

+90 (332) 237 30 30

www.konoven.com

info@konoven.com

ISTANBUL SHOWROOM

Zuhuratbaba Mah. Yüce Tarla Cad.

No:69 D:3 Bakırköy/İstanbul/TÜRKİYE

Zorman Kurumsal Gıda Mak. Ltd. Şti.

+90 (532) 012 35 74

+90 (536) 617 24 58

zorman@zorman.com.tr

+90 (212) 877 35 42

www.zorman.com.tr



www.konoven.com

konoven /

